

FAQs on Bushing Monitoring



On-Line Monitoring Inc.
300 National Road, Suite 400
Exton, PA 19341
(484) 875-0735
www.on-lineinc.com

Rev. 1 (06/04)

PFLive Products – Frequently Asked Questions

Q: What is the principle of operation and how does it differ from other techniques?

A: The power factor (PF) or $\tan \delta$ calculation in the PF Live (and the SOS) system is based on the conventional and fundamental Schering Bridge used in laboratories. Data is acquired under software control from transducers connected to the test objects associated with a transformer and then the data is compared to data from another reference standard to produce a power factor value. Our sensor monitoring these minute phase and voltage changes has been proven to detect the incipient fault days before other competitive systems in side by side tests conducted by more than one Industry studies.

The Schering bridge concept is used, where a voltage reference is taken from a bushing that simulates a reference capacitor. The reference device in our design does not have to be associated with the same phase, since the virtual Schering bridge (software algorithm) for the PF Live, will automatically make the proper phase angle adjustments. Relative measurements and evaluation can reduce the affect of influences such as ambient temperature, operating voltages, loading conditions, different aging characteristics, different designs, operating conditions, etc.

The software permits entering the PF value of the last offline test (preferred) nameplate PF values for each sample under test. Using this value, the PF is normalized to a PF result, which is comparable to an off-line test value. The current sum method is another concept used in the market. It uses the sum of the 3 phases and compares it to the neutral current. This method is very involved, has its limitations in identifying the exact failing bushing, and it has proven to be less sensitive in independent testing of bushing failures.

The common type of bushing failure problem occurs due to a failure in the internal bushing capacitive layers. These failures occur slowly over time with one layer slowly failing and burning through the kraft paper. On-Line Monitorings' method of monitoring the voltage is very responsive, and can detect these millivolt level changes. The changes are too small for a current probe to react to them. This failure does not get in to the ground until it is very late in the failure mode for the current probes to detect it. This fact was also verified by statements made by researchers at a major Canadian Hydro facility, based on their use of a current probe using the Current Sum method.

Q: Do the PF Live products need a reference voltage?

A: The PF Live products calculates the PF of a unit as a relative value compared with a reference voltage from another device that is in service, thereby eliminating the need for a standard capacitor. Please refer to the explanation in the previous question discussing the Schering Bridge..

Q: What is the impact of fluctuations of line voltage and harmonics on the readings/results from the PF Live System? This should also relate to how this affects the alarm conditions on the unit.

A: The Schering bridge method is used to directly compare the voltage signals from the monitored bushings. Changes due to load variations will be common between the phases and will therefore be factored out. The fourier analysis performed on the signals looks at the fundamental frequency only and is not affected by harmonics.

As an example of the voltage changes, note that the capacitive ratio between the bushing tap and the high side of the bushing results in a small change in the measured voltage at the test tap. For example an 83 volt change on a 500KV bushing results in a 1mV change at the test tap.

The Alarm Conditions is a figure of merit, calculated using several statistical analysis techniques on several samples. Since there are more than 10 samples used for this calculations, the impact of fluctuations of the line voltages and harmonics is totally eliminated.

Q: What is the possibility of operating the PF Live family of products in the frigid arctic environment?

A: The PF Live family of products, are certified to test at temperatures down to -50° C. The certified tests were conducted by an independent laboratory, which has verified proper operations over a temperature range of -50° to 65° C.

Q: What is length of leads provided with each sensor? Exactly what kind of wire is it?

A: The sensors for the PFLive and PFLive Plus come with 50' of cable attached. The cable as specified in the instruction manual is:

Single STP: rated for 2 kV AC insulation levels (Belden 1039A or equivalent).

Minimum shield/drain gauge $> 0.7 \text{ mm}^2$

Minimum core gauge $> 0.7 \text{ mm}^2$

Individual and overall STP bundles with several individually shielded pairs in each.

Overall shielding with drain wire.

Minimum drain wire gauge $> 1.0 \text{ mm}^2$

Q: Can a customer install into conduit, and use his own wiring?

A: The customer can install the wire in conduit, and can purchase his own cable as long as it meets the specifications in the instruction manual.

Q: What is maximum wire length from sensors to the PFLive cabinet?

A: As outlined in the **Instruction Manual**, this distance can be as long as 1,000 feet for each sample.

Q: How is the bushing/transformer protected from an accidental open circuit conditions at the bushing tap coupler?

A: The bushing tap coupler has an internal capacitor that creates a voltage divider with the bushing capacitance, $C1$. This voltage division limits the output of the bushing tap coupler to approximately 115Vrms so that it is at a safe level if it gets disconnected from the rest of the system. We also have a 400V spark gap, SG1 across the output of the bushing tap coupler that will limit the output in case of surges or an over-voltage condition. A schematic representation of the circuit is shown below.

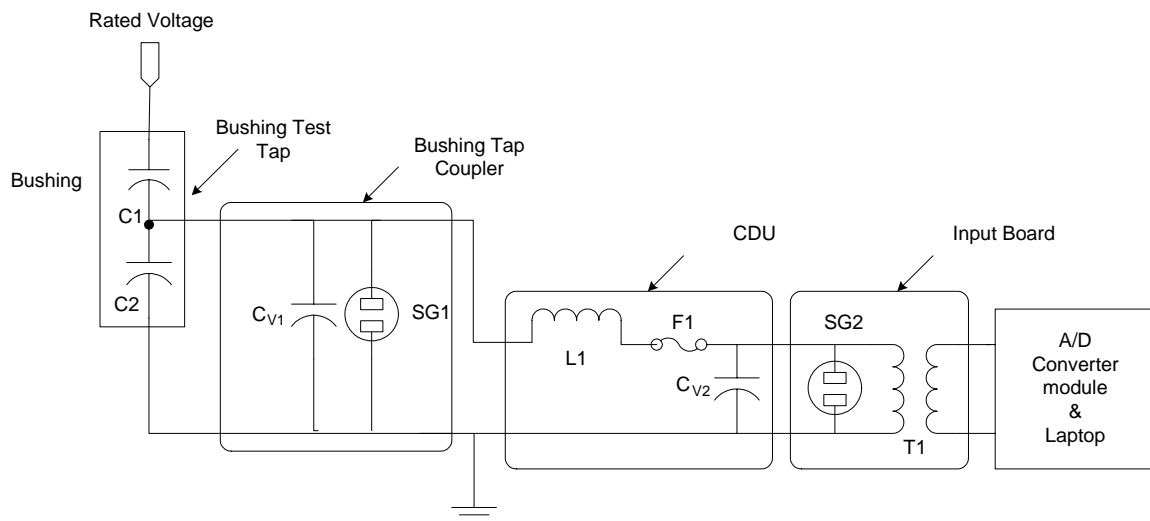

Q: You say that if I walk up to your PF Live system, I will get a reading just like the reading I would get if I used a Doble or On-Line Monitoring off-line power factor test set. Is this a true statement, and how do you do this?

A: This statement is correct. Once the PFLive is installed and configured, the user walks up with a laptop with our software and hardware installed on it and can take a live PF reading at rated voltage. (But it is an On-Line Monitoring test, not a DOBLE test)

The requirement is for configuring each sample at the initial installation. The configuration program of the PF Live software provides entering the PF value, preferably of the last offline test for each sample being connected. Using this value, the readings are normalized to a PF result, which is comparable to an off-line test value. The option to get the readings as $\tan \delta$ is also available, instead of the PF.

Q: If all of the bushings are deteriorating at the same rate, how is your system going to see a difference in the power factor reading based on a visit to this site once every three to six months?

A: The PF Live gathers the data and it can be viewed graphically or numerically. If PF values on any bushing change, it will be visible in the graphs and data, since it will not correlate with its previous data. Any changes will be noticeable from the previous test. While it is possible that all bushings could change at exactly the same rate it is very unlikely, the system will show a smaller change in data if this does occur, but it will be noticeable.

This technology has been proven on more than 1200 bushings being monitored around the world today.

Q: Is the trend reading you will be evaluating with the PF Live really an indication of what is happening to the individual bushing?

A: Yes. The power factor (PF) calculation in the PF Live Plus system is based on the conventional Schering Bridge used in laboratories. Data is acquired under software control from transducers connected to the test objects associated with a transformer and then the data is compared to data from another electrical phase to produce a power factor value. Our sensor monitoring these minute phase and voltage changes has been proven to detect the incipient fault days before other techniques in side by side tests conducted by established industry R&D Labs who have published these results..

The problem occurs due to the common type of bushing failure, which is a failure in the internal bushing capacitive layers. These failures occur slowly over time with one layer slowly failing and burning through the kraft paper. On-Line Monitorings' method of monitoring the voltage is very responsive, and can detect these millivolt level changes. The changes are too small for a current probe to react to them. The failure does not get in to the ground until it is very late in the failure stages for the current probes to detect it.

Q: Would there be a way that you could install a system on both the high and low side bushings and use calculations to give a power factor reading of the transformer itself similar to the conventional way we do with the Doble or On-Line Monitoring off line sets?

A: Not at the present time, but we are investigating other on-line tests that can be performed using the bushing taps.

Q: Why can't you just install the capacitance tap sensors at each site, run wiring to box and not install PF live unit at installation? The idea then would be to save money by carrying out a PF Live unit as well as your computer software to the site and hook up for the evaluation. Could you then get the cost to \$1000 (US\$) per point? You would only need as many PF live units as you have personnel to evaluate.

A: That is basically what we have done. The hardware reduces the signal to less than 10Vrms so the operator can safely operate the unit by creating a voltage divider between C1 of the bushing and the hardware in the PFLive.

Q: The PF Live Data is only instantaneous when polled by an operator at site. Can you provide us the capability of data storage for periods between tests that can be retrieved on a monthly basis, or longer?

A: The PF Live Plus can easily be installed in place of the PFLive to perform this function..

Q: For the PFLive Plus alarms, do we only trigger on difference of levels reached or do we also analyze 'rate of change' as a criteria for alarm?

A: The condition value is the actual condition of the bushing based on a 4 step statistical process that has been proven to be very secure. It is really a new figure of merit based on our algorithm, which has proven successful on several occasions where catastrophic failures have been prevented. The analysis is used to provide alarms based on the condition value which is based on::

- rate of change
- historical average of the data
- comparison to a like bushing exposed to the same environment
- comparison to its own reference window of data

The number of statistical tests that fail impacts the condition value of the device. This provides a check and balance to the data to ensure that it is healthy, or not.

Q: In PFLive Plus unit, what and how many outputs are provided for alarming, if any?

A: There are 2 analog output voltages available in the PFLive Plus. The output is 0 to 5 VDC, 12 bits, ± 1 bit accuracy, and can connected to a high impedance input such as a voltmeter, voltage monitor, or SCADA.

- Output voltage 1 represents the average condition value of all devices being monitored.
- Output voltage 2 represents the highest condition value of all devices being monitored.

As an example, if the highest condition value was 100% (maximum) the voltage would be 5V. If the highest condition value was 50%, the output voltage would be 2.5V.

Q: Why can't you make your device communicate with any software systems protocol?

A: We can make it communicate with any protocol, but chose IEC 61850 (UCA2) as our primary means of communication since it is in the process of becoming the only IEC/IEEE standard for substation communication. The IDD does not have an IEC 611850 interface.

We do provide alarm outputs to SCADA, and will report by exception via email or FAX. There really is no need for the customer to communicate directly to the PFLive and PFLive Plus on a regular basis.

Q: We need a RS485 output. Is this available? We do not prefer RS232. Are you limiting yourself to the IEC 61850 (UCA2) communication protocols?

A: Our system is very flexible, and we can configure one of the PFLive Plus' 4 serial ports for RS485 operation. We recommend they use a fiber optic connection from the PFLive Plus to a modem or network connection in the control house. This fiber optic connection is connected to the com1 RS232 port and can be used for a modem connection for FAXing of alarms or direct or phone line connection for PCAnywhere. The customer can use RS485 through a converter if he wants to.

The customer does not have to use IEC 61850 (UCA2). It is an option, and it separates us from our competitors, since they do not have that option available and they use a non standard command set. The RJ45 network jack in the PFLive Plus can be used without for EMAIL of alarms and data as well as a PCAnywhere access point.

There is ongoing coordinated effort to have a standardized communication protocols, which is the same for IEC and IEEE.

Q: What can be programmed on the PFLive Plus?

A: The customer may set:

- The sample rate
- Analysis periods of the monitored devices
- Frequency and type of reports
- Types of alarms that he requires.
- ASCII output via a serial port.

In addition, reports may be sent via EMAIL or FAX. The alarms can be hard wired to SCADA via output contacts. Alarms and Reports can be polled via the optional UCA interface.

The DC level inputs and alarms are user configurable independently for each DC input device.

Q: What is the maximum alarm output load/voltage etc. How many alarm outputs are provided? What do they alarm at?

A: The alarm contacts are specified in the instruction manual as:

6 Contacts, Max DC 200V, Max Current DC 1 Amp.

- A1 - Normally open. Will close if condition of unit changes from green to yellow.
- A2 - Normally open. Will close if condition of unit changes from yellow to red.
- A3 - Normally open. Will close if the signal from a single unit is down.
- A4 - Normally open. Will close if signals from a vector group (3 units) are down.
- A5 - Normally open. Will close if available disk space on the PC is below the specified percentage.
- A6 - Normally closed. Will open if the Monitoring program stops (e.g. when the operating system crashes or the PC hangs).

These contacts are the same for PFLive Plus and SOS

Q: Most all customers have indicated that their Hydrogen detectors/monitors are connected to SCADA. This takes our DC channel feature and limits its effectiveness.

A: There are thousands of Dissolved Gas Analysis (DGA) units sold world wide, the majority of them have alarm contact monitoring to SCADA. This does not allow for direct remote monitoring of the gas levels in the transformer. Our DC interface allows the voltage level output which is a representation in ppm of the overall gas in the transformer to be monitored. This is done during a walkup test with the PFLive, or continuously with the PFLive Plus and SOS. In the PFLive Plus and SOS we can trend and determine a condition value of the gas in the transformer. This condition value provides the customer with a service that he does not have today. We can also provide this information via UCA which is something that the customer cannot get directly from the Hydran without buying some other interface.

The customer can add any DC or current loop sensor output to the PFLive Plus, PFLive, and SOS to store and trend these inputs.